

ESS-AIR

ESS-AIR Engine Sound Simulator

Quick Guide for aircraft V1.0

Warning

- Consider the heat dissipation when you install ESS-AIR. The amplifier is a high-power device, which radiates heat in use. Poor dissipation might cause damage to the device.
- Set the volume based on the power of the speaker in use. If the speaker works for a long time at a power that exceeds the rated power, the speaker might be damaged.
- The speaker requires proper installation and heat dissipation. Poor installation or heat dissipation might shorten the life span of the speaker, or cause damage to the speaker.

Amplifier Instruction

- The amplifier supports 5 - 26 V input voltage. The output power changes according to the changes of the input voltage. Therefore, set the volume based on the voltage that is used.
- The amplifier supports speakers with a resistance larger than 4Ω . The speaker with 4Ω resistance generates optimum power output. When the input power exceeds 12 V, ensure proper heat dissipation.
- Select an appropriate volume to control the output power of the amplifier. When the voltage exceeds 12 V and the speaker resistance is 4Ω , the output power of the amplifier is the maximum rated power of 15 W.

Functions Description

- ESS-AIR uses advanced DNS/DCR algorithm to reproduce the sound of real engines.
- ESS-AIR supports AUX channel that can simulate a variety of sounds such as gunfire.
- ESS-AIR supports two sets of engine sounds, which enables fast switching between engine sounds.
- ESS-AIR supports RC PLUS to realize functional setting and sound purchasing from sound stores.
- ESS-AIR supports firmware updates and function upgrades.

Statement

Speakers are consumables. Incorrect installation or excessive power input causes damage to the speaker. Warranty service is not provided for speaker damage caused by incorrect installation or excessive power input.

Product Specifications

- Supply voltage range :5V-26V
- Speaker impedance : 4Ω
- AMP Output power: 15W/12V(under 4Ω)
- Number of audio channels :2
- Output is short-circuit, overload and thermally protected

Warning : Reverse power results in device damage

Packing List

ESS-AIR (SE-30D1225C) X 1
T type AMP power cable X 1
Smart Link X 1

Quick Guide X 1
Speaker (D2510W-F) X 2
Y Line X 1

RCPlus **SENSE**
Innovations

Connect ESS-AIR

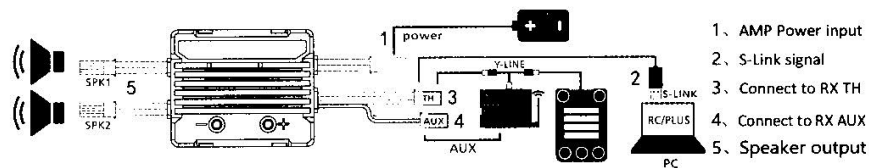

Calibrate ESS-AIR

- Enter Calibration mode : Press & hold the "+" 1S, after "DI---" sound, release the button, ESS-AIR enters the Setup mode ;
- Neutral Calibration : make sure the TH at Neutral, Click the "+", after "DI" sound, the neutral calibration finishes.
- Forward TH calibration : Pull the TH trigger to max throttle position, click the "+", after "DI" sound, forward TH calibration finishes.
- Backward TH calibration : Push the TH stick to max brake position, click the "+", after "DI" sound, the brake TH calibration finishes.
- After the steps above, "DI---", calibration is completed. Calibration mode exits automatically.
- With only "DI, DI, DI" sound, the calibration fails. It returns to the neutral calibration to re-calibration.

Volume adjustment

You can adjust volumes by click "+" or "-" .

Sound Switch

- In the running mode, long press "-". The ESS-AIR changes to set 1 sound after "DI" sound.
- Long press "-" again. The ESS-AIR changes to set 2 sound after "DI, DI" sound.

Using ESS-AIR

- Electrify ESS-AIR. ESS-AIR is in a flame-out state.
- Push the throttle toward the forward direction. The engine is started. The engine makes the sound that matches the engine speed based on the throttle signal.
- Set the flame-out switch of the remote control. ESS-AIR flames out when detecting that the throttle signal is lower than the idle throttle position.

AUX Channel

ESS-AIR supports the AUX channel function. You can trigger the gunfire sound with the AUX channel on the remote control. Download the sound of gunfire by using RC PLUS.

Other features

ESS-AIR has many additional value-added features, including sound download and replacement, upgrade of firmware and function, low battery voltage alarm, the AUX channel sound, etc. For more information about the features, visit www.sensehobby.com. The previous functions requires the use of RC PLUS.

About **RCPlus**

RC PLUS integrates configuration, sound stores and video services. It extends the ESS-AIR's powerful function. You can visit www.sensehobby.com to download the RC PLUS program and get more information.



ESS-AIR Installation Instruction

Refer to the installation of the vibration speaker

Speaker installation instruction

ESS-AIR D2510W-F speaker is a vibration speaker. Paste the speaker to the surface of a vibrating object to make a sound. The installation and the material and size of the object to which speaker is pasted influence the quality of the sound.

D25102-F Speaker Specifications

- Diameter : 54mm
- Weight: 60g
- Nominal Impedance: 4Ω
- Input Power: Nom.5W Max. 10W
- Resonance Frequency: 312Hz

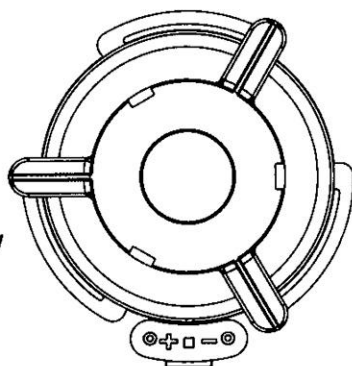

Installation Notes

- Clean the surface to which the speaker is pasted and press when you paste. For better bonding, allow for 24-hour standing. Recommendation: Use glue to paste the vibration ring.
- Install the loudspeaker as horizontally as possible. If two speakers are used, keep a distance between them.
- Paste the fixed ring and the vibration ring to the flat surface of the aircraft model. Ensure that the two rings are concentric.
- The materials and size of the mounting surface influence the sound effect. Choose the most appropriate mounting position before fixation.

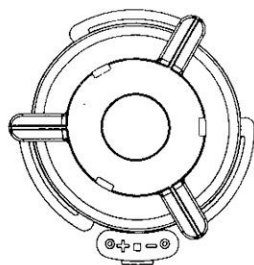

1、 Fixed ring

2、 Vibration ring

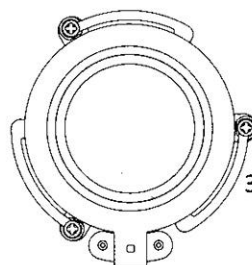

3、 Clip

Installation

Use appropriate bonding glue (e.g. ZAP) to paste the Vibration ring to the aircraft model based on the material of the surface. High-quality bonding can enhance the sound effect!

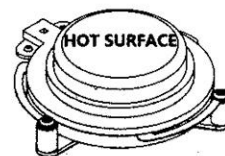
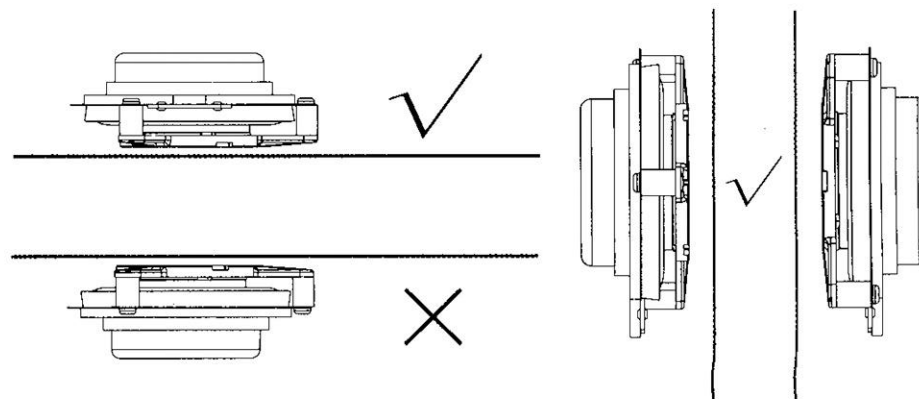

- Do not touch the speaker! The speaker in use is of high temperature.
- Keep good dissipation for the speaker.

Please use the speakers produced or recommended officially. Non-certified speakers can be problematic.

For more specifications of speakers, follow our official website www.sensehobby.com