

# LASER 2000



DESIGNED BY:

*Giuseppe Tompazini*

**SUPER PNP**  
Instruction Manual

**FLEX**<sup>TM</sup>  
INNOVATIONS



**VISIT THE LASER 200 60E PRODUCT PAGE FOR THE LATEST PRODUCT UPDATES,  
FEATURE CHANGES, MANUAL ADDENDUMS, AND FIRMWARE CHANGES FOR  
BOTH YOUR LASER 200 60E AND THE INSTALLED AURA 8 ADVANCED FLIGHT  
CONTROL SYSTEM.**

**<https://www.flexinnovations.com/product/laser-200-60e>**  
**<https://wiki.flexinnovations.com/wiki/Aura>**

## TABLE OF CONTENTS

Introduction.....	2	Transmitter Setup.....	13
Includes/Requires .....	2	Receiver Installation .....	13
Specifications .....	3	Connecting Your Receiver to Aura .....	14
Completion Items .....	3	Rudder and Elevator Linkage Installation .....	15
Replacement Parts Listing .....	3	Rudder and Elevator Linkage Installation (continued).....	16
Optional Items .....	3	Connecting Battery/Arming ESC .....	17
Before you Begin.....	4	ESC Throttle Calibration .....	17
Important Information Regarding Warranty.....	4	Control Direction Test .....	18
Safety Warnings and Precautions.....	4	Aura Sensor Direction Test .....	19
Safety Warnings and Precautions (continued) .....	5	Prop Adapter, Propeller and Spinner Installation .....	20
Important Before Assembly .....	5	Battery Installation.....	21
Battery Charging Guidelines.....	5	Center of Gravity Verification .....	21
Low Voltage Cutoff .....	5	Pre-flight Checklist.....	22
Main Landing Gear Installation.....	6	AMA Safety Code.....	22
Vertical Fin Installation.....	7	Laser 200 60E Aura Optional Features Configuration .....	23
Tail Wheel Installation .....	8	Flying your Laser 200 60E.....	24
Horizontal Stabilizer Installation .....	9	Airframe Repairs .....	25
Main Wing Installation.....	10	Replacing Servos .....	25
Night Laser 200 60E LED Connections.....	11	Aircraft Troubleshooting Guide.....	26
Connecting a Battery to the LED Controller .....	11	Limited Warranty .....	27
Aura 8 AFCS .....	12	Compliance Information for the European Union.....	27
Aura 8 Servo Connections.....	12		

---

## INTRODUCTION

### Unparalleled Flight Performance

Leo Loudenslager debuted the Laser 200 in 1975, forever changing the face of competition aerobatics. By 1982, the Laser 200 had secured seven US National championships as well as the 1980 World Championship. Inspired by this full-scale champion, F3A and 3D World Champion Quique Somenzini designed the Laser 200 60E not only to pay homage to its full-scale counterpart by maintaining the Laser 200's iconic lines but also to replicate its championship-level performance.

The Laser 200 60E pairs optimized aerodynamics with cutting-edge technology. Powered by the NEW DualSky/Flex ECO 4120C 500kv brushless motor and Genuine HobbyWing ESC, in combination with NEW Flex DS38HV servos and Aura 8 AFCS (Advanced Flight Control System), it creates a new level of performance that revolutionizes what one can expect from a foam XA/3D aircraft — much like the impact the full-scale version had on global aviation.

With top-end performance and iconic lines, the Laser 200 60E is available in both day and night versions, as well as two incredible schemes: the retro 1980 World Championship tribute scheme and the modern Clint Sweet Designs "XA Scheme", ensuring you stand out at the airfield.

From its homage to the iconic lines of the Laser 200 to its championship-level prowess, this model stands as a testament to the spirit of innovation and excellence that defines Flex Innovations. Experience a new era in aerobatics with the Laser 200 60E — where history meets cutting-edge technology.

For the latest updates, features, addendums and more, before assembly, please visit:

<https://www.flexinnovations.com/product/laser-200-60e>

<https://wiki.flexinnovations.com/wiki/Aura>

---

## INCLUDES

- Laser 200 60E airframe with decals applied.
- Aura 8 Advanced Flight Control System (programmed and ready to use).
- DualSky/Flex ECO 4120C 500kv Brushless Motor..
- Hobby Wing 80 V2 ESC with 7.4A BEC.
- Flex Innovations 16x6 Propeller for Electric Airplanes
- (4) Potenza DS38HV High Performance Mini Digital Servo.

## REQUIRES





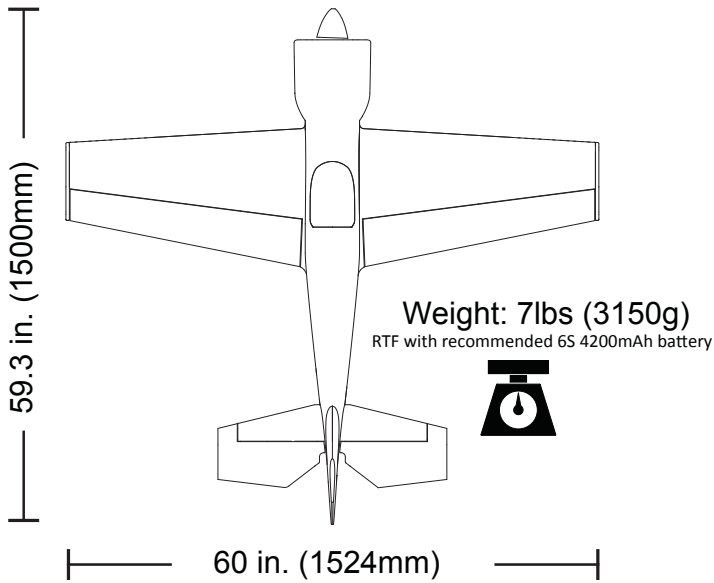



- 3500mAh - 4200mAh 6S 22.2V 35C+ LiPo Battery (FPZB42006S40 recommended).
- Minimum 6+ channel computer transmitter.
- Serial capable receiver to match your transmitter, e.g. Spektrum 4651T or Futaba R2001SB.
- 6S LiPo capable battery charger.

## SPECIFICATIONS



Recommended battery – 6S 3500mAh-4200mAh 35C+ LiPo

## COMPLETION ITEMS

<b>INSTALLED!</b>		DualSky/Flex ECO 4120C 500kv Brushless Motor (FPZMECO4120C-8)
<b>INSTALLED!</b>		Hobby Wing 80A V2 ESC with BEC 7.4V (HW80ESC-HV)
<b>INSTALLED!</b>		Flex Innovations DS38HV Digital Metal Gear Mini Servo (FPZDS38HVA, FPZDS38HVB)
<b>INSTALLED!</b>		Aura 8 Advanced Flight Control System (FPZAURA08)
		Flex Innovations 16x6 Propeller (FPMP1606E)
<b>NEEDED TO COMPLETE</b>		3500-4200mAh 6S 35C+ LiPo (FPZB35006S40, FPZB42006S40)
<b>NEEDED TO COMPLETE</b>		6+ Channel Computer Transmitter
<b>NEEDED TO COMPLETE</b>		Serial-Capable Receiver

## REPLACEMENT PARTS LISTING

FPM5170A	Laser 200 60E Super PNP Blue/Red Day
FPM5170B	Laser 200 60E Super PNP Orange Day
FPM5180A	Laser 200 60E Super PNP Blue/Red Night
FPM5180B	Laser 200 60E Super PNP Orange Night
FPM517001	Laser 200 60E: Fuselage, Day
FPM517002L	Laser 200 60E: Left Wing, Day
FPM517002R	Laser 200 60E: Right Wing, Day
FPM517003	Laser 200 60E: Tail Set
FPM517004	Laser 200 60E: Canopy / Hatch Set
FPM517007	Laser 200 60E: Wing Tube & Stab Tube Set
FPM517008	Laser 200 60E: Pushrod Set
FPM517009	Laser 200 60E: Decal Set, Blue
FPM517010	Laser 200 60E: Decal Set, TBD
FPM517011	Laser 200 60E: Hardware Set
FPM517012	Laser 200 60E: Pilot
FPM517013	Laser 200 60E: SFG Set
FPM517014	Laser 200 60E: Battery Tray
FPM517015	Laser 200 60E: Spinner
FPM517016	Laser 200 60E: Cowling with screws
FPM517017	Laser 200 60E Tail Wheel Set
FPM517018	Laser 200 60E: Spinner
FPM518001	Laser 200 60E: Fuselage, Night
FPM518002L	Laser 200 60E Left Wing, Night
FPM518002R	Laser 200 60E Right Wing, Night
FPM518003	Laser 200 60E: Stabilizer spotlight & LED set
FPZDS38HVA	Flex Innovations DS38HV Digital Metal Gear Mini Servo (400mm Wire) - Used on ailerons
FPZDS38HVB	Flex Innovations DS38HV Digital Metal Gear Mini Servo (700mm Wire) - Used on elevator and rudder
FPM337005	QQ Cap 232EX / Laser 200 60E Aluminum Landing Gear
FPM447021	60-Size Battery Tray Thumb Screw
FPM397017	Mamba / Cap 232 / Laser 200 60E Wheel Pant / Wheel Set
FPZMECO4120C-8	DualSky/Flex ECO 4120C 500kv Brushless Motor
FPMP1606E	Flex Innovations 16x6 Propeller for Electric Airplanes
HW80ESC-HV	Hobby Wing 80A V2 ESC with BEC 7.4V
FPZAURA08	Aura 8 Advance Flight Control System

## OPTIONAL ITEMS

FPM477023	QQ Cap 232/ Laser 200 60E Carbon Fiber Landing Gear
FPM337022	Cap 232: Wing Bag Set
FPZB35006S40	Potenza 6S 3500mAh 40C Li-Po Battery
FPZB42006S40	Potenza 6S 4200mAh 40C Li-Po Battery
FPZB5003S25	Potenza 3S 500mAh 25C Li-Po Battery (night flight)
SPMXC2000	Spektrum SMART S2100 G2 AC Charger 2X100W
SPMXBC100	Spektrum XBC100 Smart Lipo Battery Checker
FPMPF1606EW	Flex Innovations 16x6 Wood 2 Blade Propeller for Electric Airplanes
SPM4651T	DSMX SRXL2 Serial Telemetry Receiver
SPMR8200	Spektrum NX8 Transmitter Only
FUTT6K	Futaba T6K Transmitter with R3006SB Rx Mode 2
FUTR2001SB	Futaba R2001SB SFHSS S-Bus

## BEFORE YOU BEGIN

### SPECIAL LANGUAGE DEFINITIONS

The following terms are used throughout the product literature to indicate various levels of potential harm when operating this product:

- NOTICE:** Procedures, which if not properly followed, create a possibility of physical property damage AND a little or no possibility of injury.
- CAUTION:** Procedures, which if not properly followed, create the probability of physical property damage AND a possibility of serious injury.
- WARNING:** Procedures, which if not properly followed, create the probability of property damage, collateral damage, and serious injury OR create a high probability of serious injury.

#### WARNING

## AGES 14+

This is NOT a toy! This product is not intended for use by children under 14 years of age without direct adult supervision.

#### ATTENTION

Read the ENTIRE instruction manual to become familiar with the features and assembly of the product before operating. Failure to assemble or operate the product correctly can result in damage to the product, personal property, and cause serious or fatal injury.

All instructions, warranties and other collateral documents are subject to change at the sole discretion of Flex Innovations, LLC. For up-to-date product literature, please visit our website at [www.flexinnovations.com](http://www.flexinnovations.com) and click on the Laser 200 60E and Aura 8 product pages.

#### NOTICE

**Do not use thread locker when attaching plastic parts, the parts will soften and fail.**

#### NOTICE

**The assembly of the Laser 200 60E can be accomplished in a few hours. Prior to assembling the airplane, it is advisable to charge your battery so that you are ready to begin radio setup upon completion of the assembly of your model.**

## IMPORTANT INFORMATION REGARDING WARRANTY

Please read our *Warranty and Liability Limitations* section before building this product. If you as the purchaser and/or user are not prepared to accept the liability associated with the use of this product, you are advised to return this product immediately, in new and unused condition, to the place of purchase.

## SAFETY WARNINGS AND PRECAUTIONS

Protect yourself and others by following these basic safety guidelines.

1. This manual contains instructions for safety, operation, and maintenance. It is essential to read and follow all the instructions in the manual, prior to assembly, setup, or use, in order to operate correctly and avoid damage or serious injury. In some cases, the written instructions may differ slightly from the photos. In those instances, the written instructions should be considered correct.
2. This model is not a toy, rather it is a sophisticated remote control hobby product and must be operated with caution and common sense. This product requires some basic mechanical ability. Failure to operate this product in a safe and responsible manner could result in injury, or damage to the product, or other property.
3. This model must be assembled according to these instructions. Do not alter or modify the model outside of these instructions provided by Flex Innovations, LLC, as doing so may render it unsafe and/or un-flyable. You must take time to build straight, true, and strong. It is your responsibility to ensure the air-worthiness of this product.
4. Use only compatible, appropriate components for the final assembly of this model. Ensure that the radio system is in functional condition, that the motor is appropriately sized for the model and that all other components are appropriate for use in this model as specified in this Laser 200 60E Instruction manual. All components must be installed correctly so that they operate correctly both on the ground and in the air.
5. Inspect and check operation of the model and all its components before every flight.

## SAFETY WARNINGS AND PRECAUTIONS (CONTINUED)

6. If you are not an experienced pilot, or have not flown a high-performance model before, it is recommended that you seek assistance from an experienced pilot in your R/C club for your first flights. If you're not a member of a club, the Academy of Model Aeronautics (AMA) has information about clubs in your area whose membership includes experienced pilots.
7. Keep the propeller area clear from such items as loose clothing, jewelry, long hair, or tools, as they can become entangled. Keep your hands and body parts away from the propeller as injury can occur.

---

## IMPORTANT BEFORE ASSEMBLY

Carefully unpack your aircraft and inspect the parts. Review the manual and gather all the required tools and supplies.

- Remove all parts from their plastic bags, inventory all items and closely examine all the major airframe components for damage. If any items are missing or you find damaged components, do not proceed, please contact customer support.
- Use thin CA to go over any important glue joints, such as the motor box, firewall, servo mounting rails and any other pre-assembled joints that may see high stress during flight.
- Gather all required components such as motor and radio equipment that will be used to equip the airplane. Create a new radio program in your transmitter and bind this model program to the receiver that will be used in the airplane

---

## BATTERY CHARGING GUIDELINES



### WARNING

**Follow all instructions provided by your battery and charger manufacturer. Failure to comply can result in fire.**

We recommend the use of an advanced LiPo balancing charger, such as the Spektrum Smart S2100 G2 AC 2X100W Charger for your batteries to get the maximum performance and lifespan from them.

Our airplanes are designed around our Potenza LiPo batteries, and we recommend the Potenza 6S 4200mAh 40C LiPo in the Laser 200 60E based on our extensive testing and development. These batteries feature an EC5 connector, so no soldering is required for use in your Laser 200 60E.

All are available online at [www.flexinnovations.com](http://www.flexinnovations.com) and your local Flex Innovations retailer.

---

## LOW VOLTAGE CUTOFF

LiPo batteries have a nominal (rated) voltage of 3.7v per cell, and fully charged, reach 4.2v per cell. Batteries are designed to be discharged below the nominal voltage, however, if they are discharged below 3.0v per cell, damage will occur and the pack will lose capacity. For best long term battery life, set a timer and land after a time that leaves approximately 15% of the battery's capacity remaining.

Low voltage cutoff is a feature that is built into the HobbyWing 80A ESC that is designed to protect the connected battery from being discharged too far and causing permanent damage to the cells. Circuitry within the ESC will automatically detect when the input voltage from the battery pack reaches below 3.0V per cell (average) and will remove power to the motor, but still deliver power to the servos so that a safe landing may be made. If the motor begins to lose power rapidly during flight, the LVC has sensed that the total voltage of the pack has dropped below 3.0V per cell average, and the airplane should be landed immediately.

## MAIN LANDING GEAR INSTALLATION

### Required Tools and Fasteners:



(QTY 2)    (QTY 4)    (QTY 4)

#1 Phillips Screwdriver  
8mm Open End Wrench  
12mm Open End Wrench  
Adjustable Wrench (optional)

(2) M3x10 Phillips Head Machine Screw  
(4) M3x12 Phillips Head Self-Tapping Screw  
(4) M3x15 Phillips Head Machine Screw  
Blue Thread Lock

1. Mount the main landing gear to the fuselage using four M3x15 screws and thread locker.
2. Mount the main gear shafts and tires to the landing gear using a M4 washer, an M4 nut and thread locker.
3. Take apart the wheel pants. Slide the inside wheel pants down over the wheel and shaft and mount them to the landing gear using M3x10 screws and thread locker.
4. Secure the outside of the wheel pants to the inside using two M3x12 self tapping screws per side.

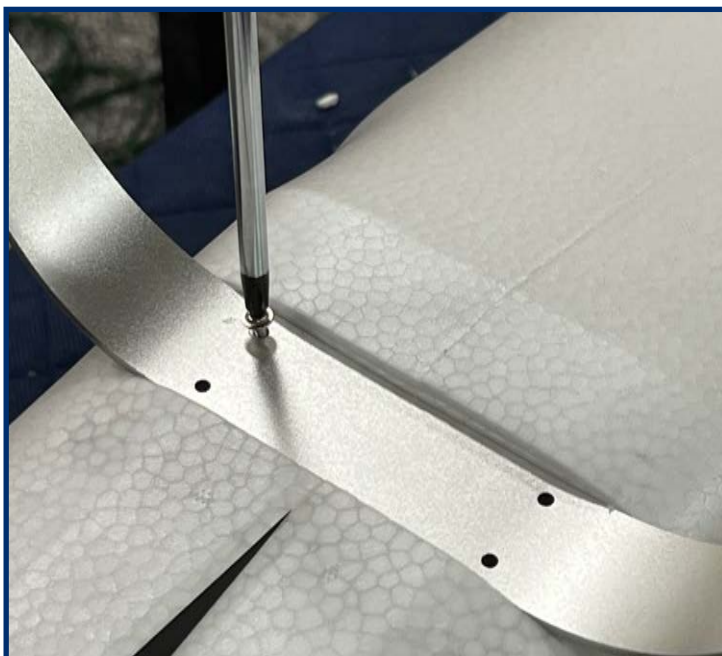
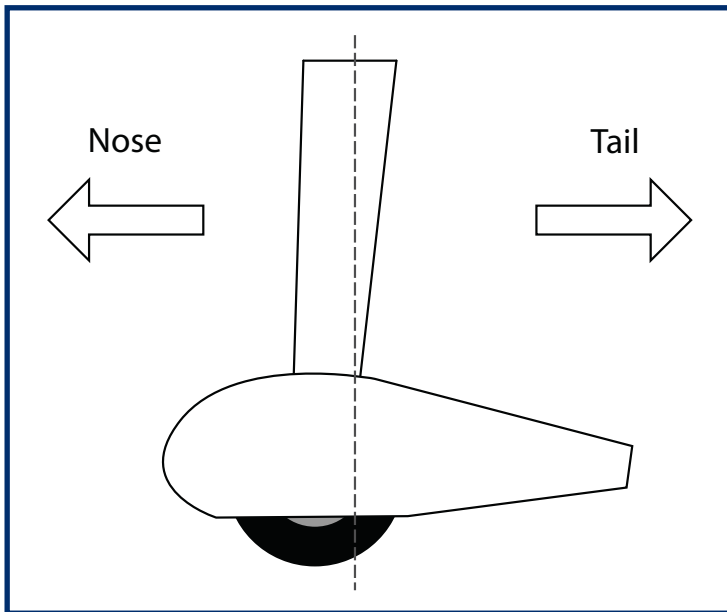

## VERTICAL FIN INSTALLATION

### Required Tools and Fasteners:



(QTY 1)

#1 Phillips Screwdriver  
30-Minute Epoxy  
Paper Towels  
Isopropyl Alcohol

(1) M3x10 Phillips Head Self-Tapping Screw  
Craft Sticks (for mixing epoxy)  
Mixing Cup

1. Dry fit the vertical fin to the fuselage.
2. Once everything fits correctly, clean all surfaces with rubbing alcohol before bonding.
3. Bond the vertical fin assembly to the fuselage using medium CA or 15-minute epoxy adhesive. Ensure that you get adhesive on all the mating surfaces.
4. Clamp the vertical fin assembly in place while the adhesive dries.
5. Secure the bottom of the rudder using an M3X10 self tapping screw, don't over-tighten, the rudder must be free to rotate.





## TAIL WHEEL INSTALLATION

**Required Tools and Fasteners:** #1 Phillips Screwdriver

(3) M3x10 Phillips Head Self-Tapping Screw



1. Insert the tail wheel into the slot in the bottom of the rudder.
2. Secure the retaining plate to the rudder fin using three M3x10 self tapping screws.



## HORIZONTAL STABILIZER INSTALLATION

Required Tools and Fasteners: #1 Phillips Screwdriver

(4) M2.6x8 Phillips Head Self-Tapping Screw



1. Insert and roughly center the carbon fiber horizontal stabilizer tube in the fuselage.
2. Insert both halves of the horizontal stabilizer onto the tube. Ensure that the control horn faces the bottom of the fuselage and that the elevator jointer tabs line up properly.
3. If you have the night version, connect the LED power connectors.
4. Once both halves of the horizontal stabilizer are seated in place secure them each using two M2.6x8 self tapping screws.  
**Note: DO NOT use thread locker on these screws, it will melt the plastic!**

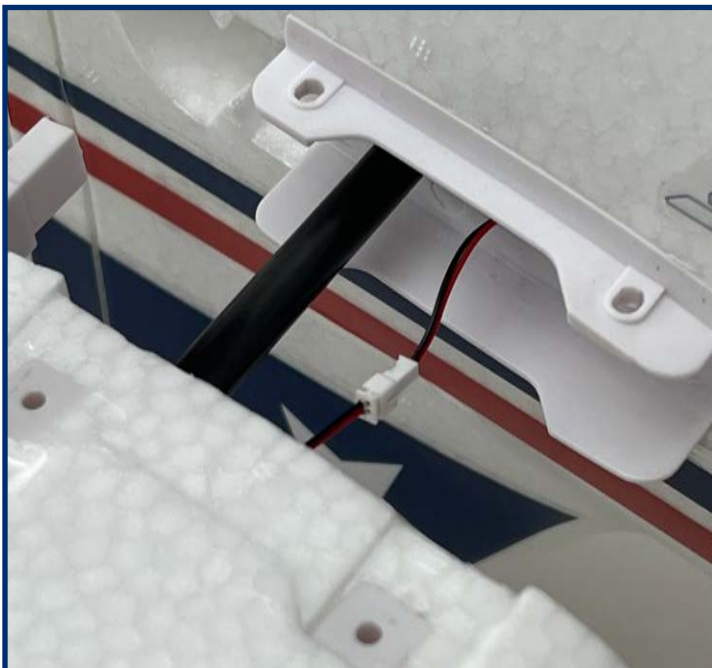

## MAIN WING INSTALLATION

### Required Tools and Fasteners:

- (2) M4x18 Thumb Machine Screw
- (4) M5X35 Nylon Thumb Screws

#2 Phillips screwdriver



(QTY 2)



(QTY 4)

### WARNING

**REMOVE THE AILERON SERVO HORN SCREWS AND APPLY BLUE THREAD LOCK TO THE SCREWS. RE-INSTALL THE SCREWS AND TIGHTEN FULLY. FAILURE TO DO SO MAY RESULT IN A CRASH**

1. Remove the hatch from the fuselage.
2. Insert and roughly center the carbon fiber wing tube in the fuselage.
3. Slide the left and right wing panels onto the tube. Ensure the servos orient to the bottom of the fuselage.
4. Connect the aileron servos to the corresponding ports in the Aura 8 (see page 12 for port assignments).
5. If you have the night version, connect the wings to the LED controller using the red JST power connectors.
6. Seat the wings completely in the wing saddles and secure the wings using the thumb screws through the aluminum tabs.
7. Screw on the side force generators using two M5X35 nylon screws each, the plastic scuff guard should face downwards. Do not over tighten.

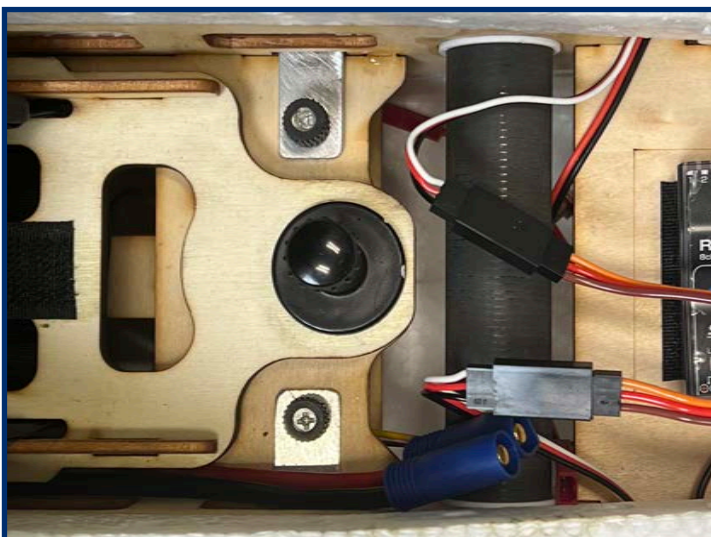
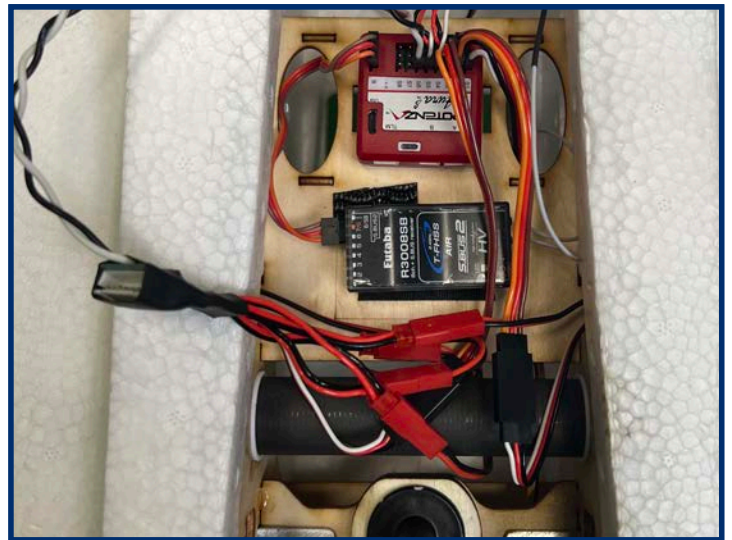

## NIGHT LASER 200 60E LED CONNECTIONS

If you have purchased the Night version of the Laser 200 60E, this page will cover all LED light connections. If you did not purchase the night version, skip ahead to the next page.

1. There is a connection for each wing panel in the LED controller and a connection for each horizontal stabilizer half in the opening by the stabilizer on each fuselage side.
2. When installing the horizontal stabilizers, connect the horizontal stab connectors (small white connectors) to the wires that are routed to the openings where you install the horizontal stab halves, one on each side of the fuselage.
3. When installing the wings, connect each one of the wing connectors to one of the two free red JST connector on the LED controller in the fuselage.
4. Once the wings have been connected all four of the red JST LED power connectors in the controller will be occupied. One powers the right side of the fuselage and right stab LEDs, one powers the left side of the fuselage and left stab LEDs and the last two are for the wing LEDs

---

## CONNECTING A BATTERY TO THE LED CONTROLLER

The LEDs on your aircraft are switchable via the transmitter, and are designed to be powered by 12 volts (3S LiPo) through the 6S JST-XH balance tab on the LED controller.

### NOTICE

**If you want to remotely switch the LEDs on your Night Laser 200 60E on or off then the LED controller should be plugged into port S6 in the Aura 8. If the servo lead of the LED controller is not plugged into the Aura, the LED controller will default to the ON position when powered.**

### ! WARNING

**You MUST use an independent 3S Li-Po battery to power the LEDs in the Laser 200 60E. Failure to do so can damage your flight batteries. We recommend the use of the Potenza 3S 500mAh 25C Li-Po (FPZB5003S25).**

### ! WARNING

Do not leave the battery plugged into the LED controller for extended periods of time. Doing so can damage the battery. Average current draw for the lighting system is 2.2A/h

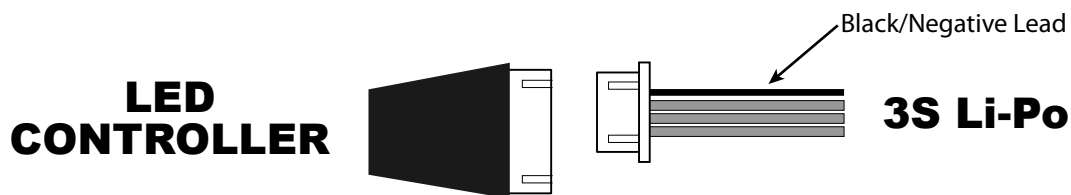

## AURA 8 AFCS

The Aura 8 AFCS (Advanced Flight Control System) comes programmed and pre-installed in your Laser 200 60E, making setup a breeze. This highly-refined 3-axis gyro makes the Laser 200 60E fly like it is a larger aircraft and in less wind. Thanks to the Aura's advanced implementation, it not only enhances the flying experience, but it never interferes with the pilot's control.

The Aura 8 AFCS comes configured with Flight Modes (dual rates, expos and gyro settings) set by the Flex Innovations team, and offers a great starting point for most pilots. **Since these are already configured for you in the Aura, there is no need to set up dual rates or expos in your transmitter.** Simply follow the Transmitter Configuration Guide in this manual for complete details on the transmitter programming required for the Laser 200 60E and Aura 8 AFCS.

Visit [wiki.flexinnovations.com/wiki/Aura](http://wiki.flexinnovations.com/wiki/Aura) for the latest Aura-related product information and updates.

The following shows the pre-configured Aura flight modes in the Laser 200 60E.

### Laser 200 60E Aura Profile

#### Flight Mode 1: Sport (Gyro On)

- For general flight
- Rates are low and expos tuned for general flight
- Gyro is set to low

#### Flight Mode 2: Extreme Aerobatics (Gyro On)

- For more advanced aerobatics like tumbles and spins while at high airspeeds
- Rates are highest and expos are tuned for comfortable flight
- Gyro is set to low

#### Flight Mode 3: Slow Speed 3D (Gyro On)

- For slow speed, 3D flight
- Rates are highest and expos are tuned for comfortable flight
- Gyro is set to its highest setting and may oscillate in high speed flight under certain conditions

NOTE - Rudder stick movement will also move the ailerons and elevator. This is NORMAL and is the pre-programmed mixing.

Each of the modes has been tuned by our team to offer a solid start. Because tastes in control feel are unique, if changes in rate and expo are needed adjustments should be made through Aura. Changes on gain value can only be made through the Aura.

The Aura 8 AFCS Profile for the Laser 200 60E can be enhanced with optional features without the need of a computer. For further details, please see the section of this manual titled **Laser 200 60E Aura Optional Features Configuration** on page 23.

## AURA 8 SERVO CONNECTIONS

### DEFAULT AURA CONNECTIONS

- S1 – Throttle**
- S2 – Left Aileron**
- S3 – Right Aileron**
- S4 – Elevator**
- S5 – Rudder**
- S6 – LED Controller**
- Port B – Serial Receiver Input**

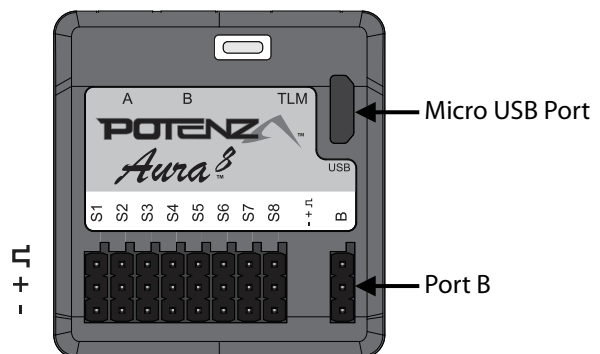

## TRANSMITTER SETUP

The included Aura 8 is designed to work seamlessly with all popular transmitter and receiver brands, however, transmitter setup is significantly different than when setting up a model without Aura. Follow these steps:

1. Start with a new model memory in your transmitter. Reset it to be certain it is set to defaults.
2. Adjust your transmitter settings according to the Transmitter Configuration Guide below.
3. **Make ONLY the changes shown in the Transmitter Configuration Guide.** No other changes are required.

### Transmitter Configuration Guide

	Spektrum, Futaba, JR & Graupner	FrSky	Jeti (EX-Bus)
<b>Wing/Tail Type</b>	1 Aileron, 1 Elevator, 1 Rudder	1 Aileron, 1 Elevator, 1 Rudder	1 Aileron, 1 Elevator, 1 Rudder
<b>End Points (Travel Adjust or ATV)</b>	Ail/Ele/Rud – 125%	Ail/Ele/Rud – 100%	Aileron/Ele/Rud – 100%
	Thro/CH5/CH6 – 100%	Thro/CH5/CH6 – 84%	Thro/CH5/CH6 – 80%
<b>Reversing</b>	<b>Not Allowed</b>		
<b>Sub-Trim</b>	<b>Verify at Zero, NOT ALLOWED</b>		
<b>Trim Levers</b>	<b>Verify at Zero</b>		
<b>CH5 (Gear) – Flight Mode</b>	<b>Assign to a 3 Position Switch</b>		
<b>CH6 (Aux 1) – LEDs On/Off<sup>1</sup></b>	<b>Assign to a 2 Position Switch</b>		
<b>CH7 (Aux 2) – Gyro On/Off<sup>2</sup></b>	<b>Assign to a 2 Position Switch</b>		
<b>First Flight Timer</b>	<b>For your first flight, set to 4:00</b>		

- 1 This is only required to switch the LEDs On/Off via the transmitter. If the LED controller is unplugged from the receiver or Aura 8, the lights default to the ON position when powered.
- 2 The default Aura program has Gyro On/Off disabled, see page 23 for instructions on using Quick Set to enable Gyro On/Off.

### NOTICE

**FOR CUSTOMERS USING TRANSMITTERS OTHER THAN WHAT IS LISTED IN THE CHART ABOVE, PLEASE VISIT OUR WIKI PAGE FOR INSTRUCTIONS SPECIFIC TO YOUR TRANSMITTER AND RECEIVER BRAND**

**HITEC – [wiki.flexinnovations.com/wiki/Aura/HitecSbusUse](http://wiki.flexinnovations.com/wiki/Aura/HitecSbusUse)**

## RECEIVER INSTALLATION

### Choosing a Receiver

Aura will auto-detect modern serial receiver connections. For use in the Laser 200 60E, only a serial receiver connection can be used. Below are a few examples of serial receivers that can be used with the Aura 8. This is not a complete list of compatible receivers, rather a short list to assist in your receiver selection.

- Spektrum SRXL** – SPMAR6610T, SPMAR8020T, SPMAR10100T
- Spektrum SRXL2** – SPM4651T, SPM4650
- Futaba S.Bus** – Futaba R7008SB, R2001SB, R6202SBW
- Hitec S.Bus** – Optima SL, Maxima SL
- FrSky S.Bus** – RX4R, RX6R
- Graupner HoTT (Sum D of 8)** – GR12L, GR16L
- JR XBus (Mode A & Mode B)** – RG012BX, RG613BX, RG821BX
- Jeti EX-Bus** – REX10, R9 EX, REX6

Note: Single or Dual DSMX Remote Satellites are not allowed in the Aura Mini Port A and Aura Mini Port B due to the size and power of the Laser 200 60E.

## CONNECTING YOUR RECEIVER TO AURA

### Serial Receivers

If using a standard serial receiver, connect the provided male to male cable to your receiver's serial port. Connect the other end of the cable to Aura Port B noting proper polarity.

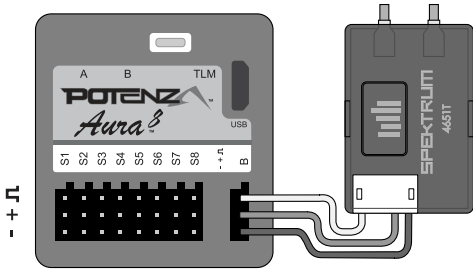

Note: SRXL2 receivers like the 4651T or the AR6610T require the use of a different cable to connect to Aura. The cable is included with the receiver when it is purchased directly from Flex Innovations. You can also purchase the cable itself at [flexinnovations.com](http://flexinnovations.com) (FPZA1039).

Note: If you are using Futaba S.Bus, be sure to use the proper S.Bus port in your receiver. DO NOT use the S.Bus2 port, as it is not supported for use with the Aura 8. Refer to your manufacturer's instructions for proper S.Bus use.

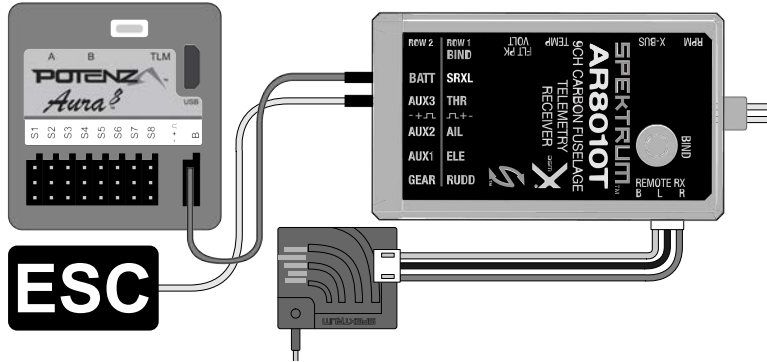
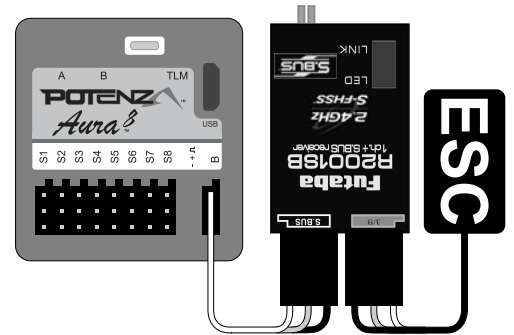

Note: When using Spektrum SRXL or SRXL2 to connect to the Aura, always connect the remote receivers to the Spektrum receiver, NOT to the Aura.

### Binding Your Receiver

Bind your receiver to your transmitter per your receiver and transmitter manufacturer's instructions.

### Aura 8 Auto-Detect

Once your receiver is bound, powered, and connected to the Aura, the Aura will begin the Auto-Detect process to learn what type of receiver you are using and set itself up for that specific system. Auto-Detect is indicated by a series of sweeping LEDs of various colors. After Auto-Detect is completed, verify that Aura is on and receiving data from your receiver by looking at the LEDs on the Aura.

#### Ready-To-Fly:

**Solid Orange LED:** Aura On and Calibrated

**Solid Green LED:** Aura receiving Valid receiver data



#### Possible Errors:

**Flashing Orange LED:** Aura Moved During Power Up

**No Green LED:** Aura NOT receiving receiver data



## RUDDER AND ELEVATOR LINKAGE INSTALLATION

### Required Tools and Fasteners:

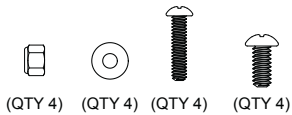

Elevator and Rudder Pushrod Assemblies  
(4) M2x10 Phillips Head Machine Screw  
(4) M2 Flat Washer  
(4) M2 Lock Nut  
(4) M3x6 Phillips Head Machine Screw

#2 Phillips Screwdriver  
#0 Phillips Screwdriver  
Needle-Nosed Pliers (or Hemostats)  
Blue Thread Lock

1. Locate the rudder and elevator pushrod assemblies, as well as the servo arms and hardware. Note that both servo arms are the same length but the elevator pushrod is slightly longer than the rudder pushrod.
2. Power on your transmitter, and power on the airplane. Once the Aura has initialized and you can verify that the servos are operating properly, ensure that the aircraft is stationary when making any adjustments to servo arm positions or to pushrod lengths. Since the default Aura configuration has Gyro Enabled in all flight modes you will notice that any motion of the airplane will result in a corresponding motion of the control surfaces.

### WARNING

**DUE TO VARIANCES IN PRODUCTION AND THE LARGE CONTROL SURFACE THROWS ON THIS AIRCRAFT, PROPER SERVO CENTERING AND TRAVEL ADJUSTMENT IS CRITICAL TO PREVENT SERVO OVER TRAVEL AND FAILURE. IF THE SERVO ARMS ON YOUR AIRCRAFT DO NOT SIT PERPENDICULAR TO THE SERVO CASE, YOU MUST USE THE AURA CONFIG TOOL TO ADJUST THE SUB-TRIM AND OUTPUT SCALE VALUES TO PREVENT OVER TRAVEL OF THE SERVOS.**

To download the Aura Config Tool, please visit: <https://www.flexinnovations.com/aura-config-tool-install/>





## RUDDER AND ELEVATOR LINKAGE INSTALLATION (CONTINUED)

- With the aircraft still powered on, install the rudder and elevator servo arms perpendicular to the servo case, being sure to orient the servo arm towards the bottom of the fuselage. Apply blue thread lock to the M3x6 Phillips head machine screw, and secure the servo arm in place with a #2 Phillips screwdriver.



### WARNING

**Note: Do not use thread locker on the bolts holding the push rods to the servo arms or the control horns!**

**Using thread locker will weaken the plastic, void your warranty, and cause your airplane to crash!**

- Use a #0 Phillips screwdriver, M2x10 machine screw, M2 washer and M2 lock nut to secure the linkage to the control horn and servo arm. Use the diagrams below for proper control horn and servo arm linkage locations. The sequence of the hardware components is as follows:
  - M2x10 Machine Screw
  - M2 Washer
  - Servo Arm or Control Horn
  - M2 Lock Nut
- Repeat the process for the other control linkage.

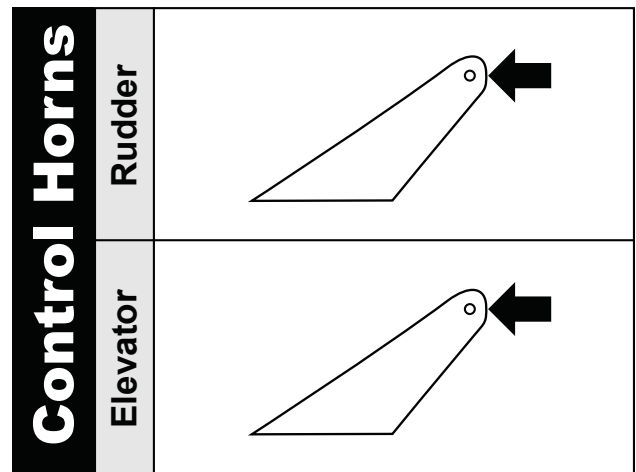
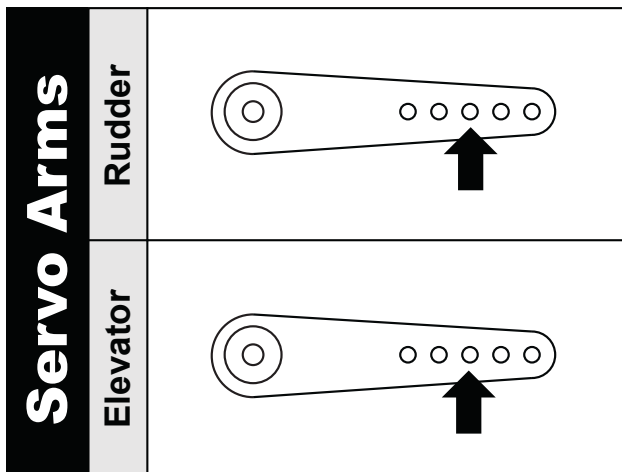

## CONNECTING BATTERY/ARMING ESC

Observe the following procedures to safely power up your model after it has been bound. **Ensure propeller is removed unless this sequence is followed to power up before flight.**

1. Turn on the transmitter. **Lower the throttle stick AND throttle trim** to their lowest settings. Be sure to wait for your transmitter to indicate it the radio signal is being broadcast before proceeding.

If a battery is connected to the ESC with the throttle fully open on the transmitter, the ESC will enter programming mode. If this occurs, simply disconnect the battery, lower the throttle and reconnect the battery.

2. Ensure the aileron, elevator and rudder gimbals are centered.
3. With the airplane on a solid surface, connect the battery to the ESC and wait. The ESC will make the motor emit a series of audible tones during its initialization process.
4. The ESC will make the motor emit a short, final tone sequence indicating that the ESC is now armed and that the motor will spin in response to throttle stick movement.

### ! WARNING

When making adjustments to linkages, transmitter settings, or the Aura 8 flight control system, remove the propeller to guard against accidental spool up.

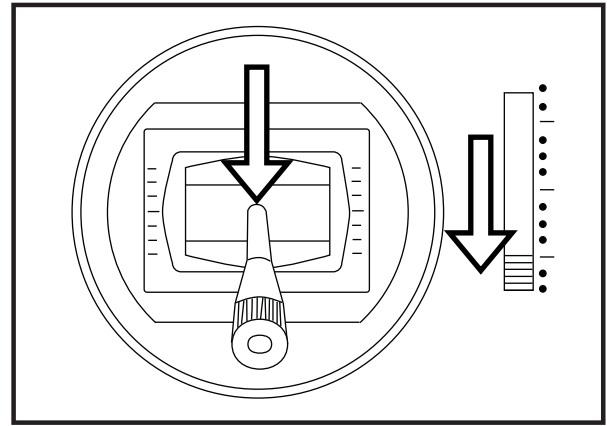

### ! CAUTION

Always connect the battery when the throttle stick and throttle trim are in the idle/cut-off position.

### ! WARNING

Hold aircraft securely when connecting the battery before flight. Always ensure that the propeller is clear of any and all objects as they may become entangled.

## ESC THROTTLE CALIBRATION

In order to map the full range of the ESC output to your throttle stick motion you will have to preform an ESC throttle calibration. **NOTE: Execute ESC throttle calibration with the propeller and spinner removed.**

1. Power on your transmitter, DISABLE any throttle hold or throttle kill switches, **completely lower the throttle trim** and set the stick to full throttle.
2. Connect the flight pack to your Laser 200 60E.
3. Listen for the tones coming from the ESC through the motor, about 2 seconds after RF is engaged you should hear two tones.
4. Pull your throttle stick back to idle.
5. Listen for the ESC arming tones from the motor.

The ESC throttle range has now been properly calibrated, and is stored in the ESC's memory until it is calibrated again. You can repeat this process as many times as necessary.

### ! CAUTION

**Note: After throttle calibration is complete it is necessary to reset the failsafe on your receiver (see your radio documentation, this may require a re-bind).**

## CONTROL DIRECTION TEST

Refer to the chart below to determine the proper control surface responses to transmitter control inputs.

**If controls are reversed, DO NOT REVERSE CONTROLS IN YOUR TRANSMITTER OR IN THE AURA CONFIG TOOL. Email us at [support@flexinnovations.com](mailto:support@flexinnovations.com) for corrective action. Note that BOTH the Transmitter Control Direction Test AND the Flight Controller Sensor Direction Test MUST BE PASSED! IF EITHER ONE DOES NOT PASS, DO NOT FLY!**

NOTE: There is pre-configured rudder to aileron and rudder to elevator mixing programmed into the Aura. Simultaneous movement of these control surfaces with rudder input is intentional and completely **NORMAL**.

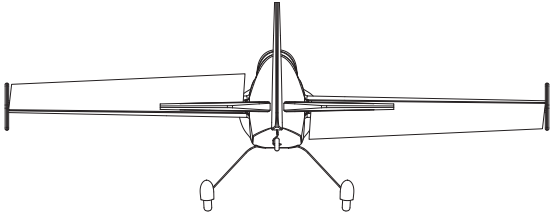
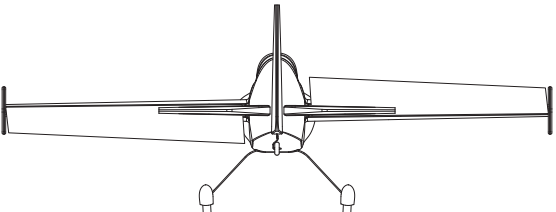
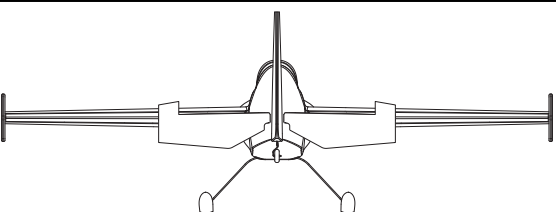
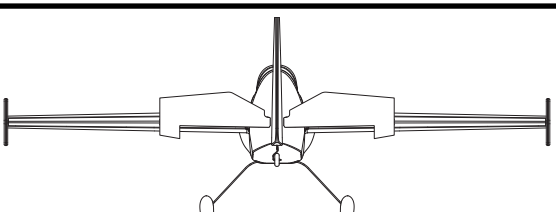
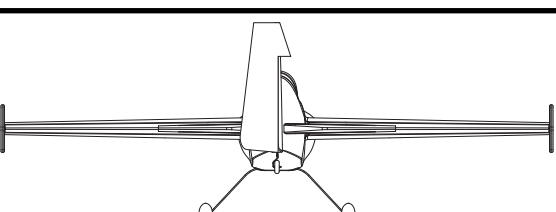
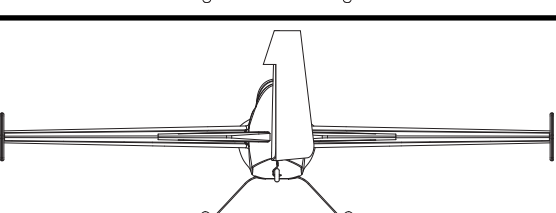
	Transmitter Command	Proper Control Surface Deflection
AILERON	Stick Left	
	Stick Right	
ELEVATOR	Stick Forward	
	Stick Aft	
RUDDER	Stick Left	
	Stick Right	

## AURA SENSOR DIRECTION TEST

Perform a test of the gyro system to verify the corrections made for a given movement are correct. **If any of the tests do not result in the correct reaction from the airplane's gyro system, DO NOT FLY THE AIRPLANE, and contact us via email at [support@flexinnovations.com](mailto:support@flexinnovations.com)**

The flight control system activates with RF broadcast. Perform these tests in Mode 3 (higher gain) for better visibility and then in Mode 2, and finally in, Mode 1. Control surface deflections are exaggerated in the pictures below for clarity. Please note that the control surfaces will move **ONLY** while the aircraft is being **ROTATED**.

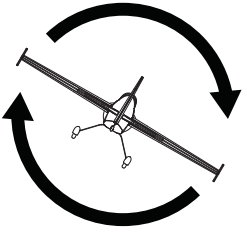
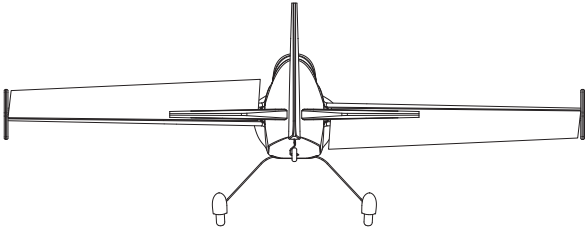
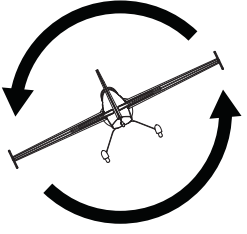
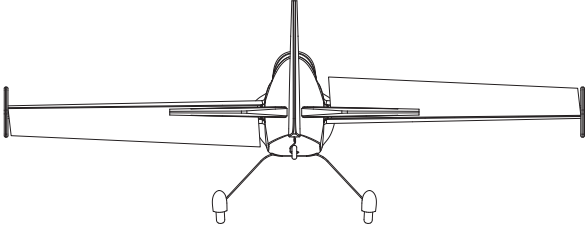
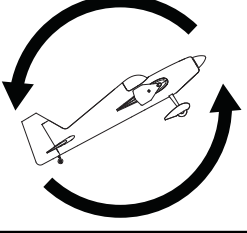
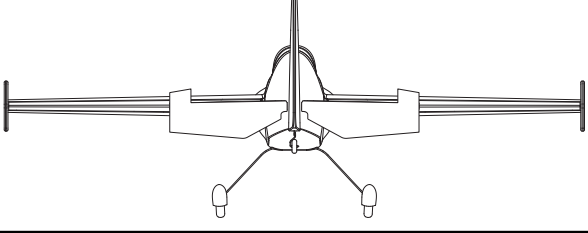
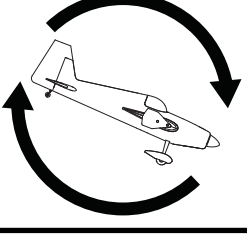
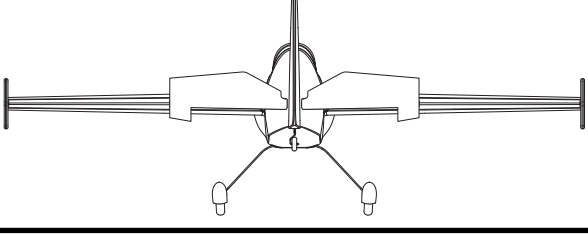
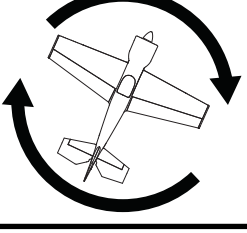
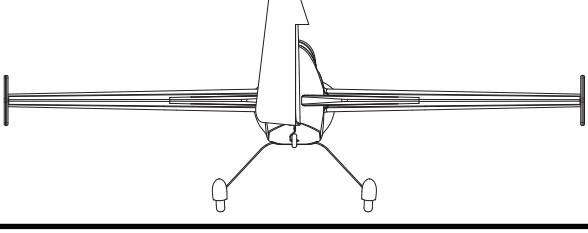
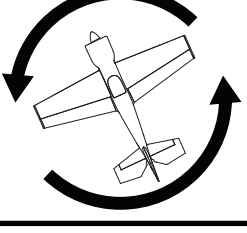
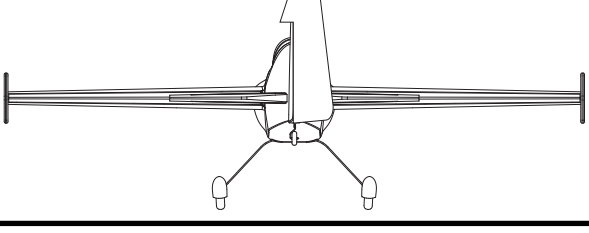
	Aircraft Movement	Proper Control Surface Deflection
AILERON		
		
ELEVATOR		
		
RUDDER		
		

## PROP ADAPTER, PROPELLER AND SPINNER INSTALLATION

### Required Tools and Fasteners:

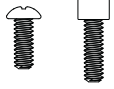

(QTY 1) (QTY 5)

(5) M3X17 Propeller Adapter Bolts  
M8 Nut & Washer for Propeller Adapter  
(1) M3X10 Phillips Button Head Screw

2.5mm Hex Wrench  
13mm Wrench or Adjustable Wrench  
#1 Phillips Screwdriver

1. Install the propeller adapter on the front of the motor using the supplied M3X17 bolts and a 2.5mm hex wrench. The bolts come from the factory with thread locker applied so there is no need to add any additional thread locker.
2. Place the propeller onto the propeller adapter, with the convex side facing forward. Place the propeller washer over the shaft, and thread the propeller nut onto the propeller adapter. Use a 13mm wrench or an adjustable wrench to tighten the propeller nut.
3. Place the spinner over the prop shaft, being sure to align the cutouts in the spinner with the propeller blades. Use a M3x10 Phillips button head screw and a #1 Phillips screwdriver to secure the spinner in place.



## BATTERY INSTALLATION

1. Push the spring-loaded battery latch tab back to release the battery hatch. Lift the hatch away from the fuselage, starting at the front.
2. Remove the battery tray by loosening the thumb screw. Slide the tray rearward as you gently lift the tray away from the fuselage.
3. Install an adhesive-backed hook strip to the battery tray, and an adhesive-backed loop strip to the battery.
4. Place the battery on the tray, and secure it in place with the hook and loop straps provided.
5. Re-install the tray into the battery compartment by aligning the front tab on the tray with the appropriate slot in the fuselage sub-frame. Once seated in place, secure the tray to the sub-frame using the thumb screw.
6. Reinstall the hatch, and confirm that the latch has positively engaged.

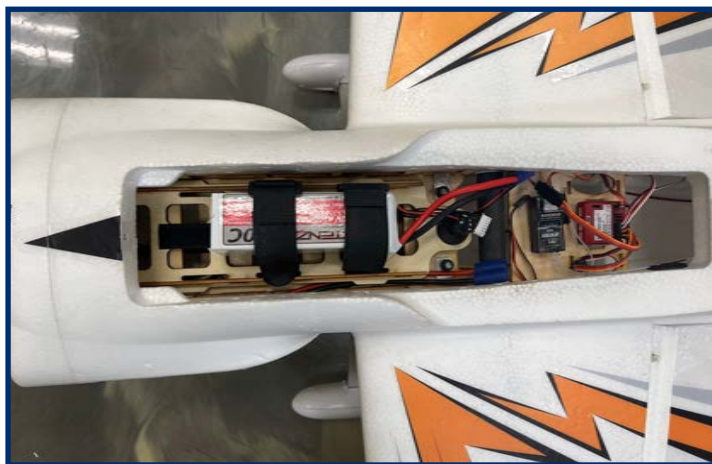
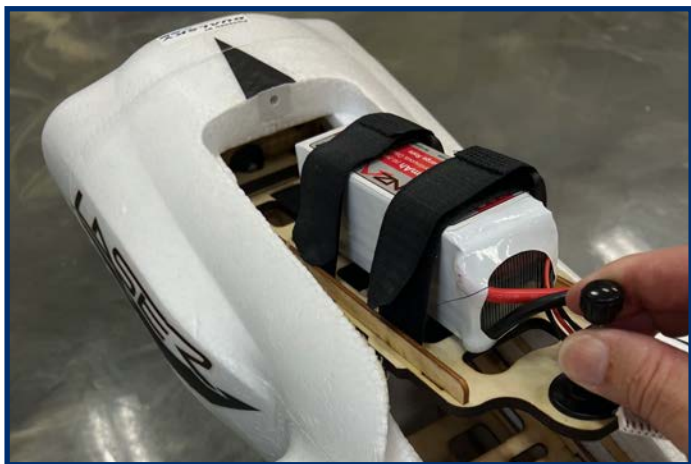

### ⚠ CAUTION

Always keep limbs clear from the propeller when the battery is connected. After the ESC arms, the propeller will rotate when the throttle is moved. Unlike an internal combustion engine, electric motors apply more voltage to counteract resistance, therefore any object that is entangled in the propeller will be severely damaged before the motor will stop

### ⚠ WARNING

**When making adjustments to linkages, transmitter settings, or the Aura 8 flight control system, remove the propeller to guard against accidental spool up.**

## CENTER OF GRAVITY VERIFICATION

The center of gravity (CG) location for your aircraft is located between the two locations provided, adjust within that range to suit your flying style.

**The recommended CG is located 5-7/8 inches (150mm) FORWARD of the trailing edge of the wing at the wing tip.**

**The acceptable range for the CG is between 6-1/8 and 5-13/16 inches (155mm and 148mm) FORWARD of the trailing edge of the wing at the wing tip.**

These CGs are measured by lifting the completed airplane upright, with all components installed. This location was determined from many test flights by designer and multi-time world aerobatic champion, Quique Somenzini. Lift the airplane from the underside of the wing to check CG.

Setting the center of gravity is one of the most important steps for success, particularly with a new airplane. The Laser 200 60E is a high-performance airplane with large control surface throws, and a high thrust-to-weight ratio. These two factors combined make it a very enjoyable aircraft to fly, but if the CG is not within an acceptable range, it will make the aircraft difficult, if not impossible to control.

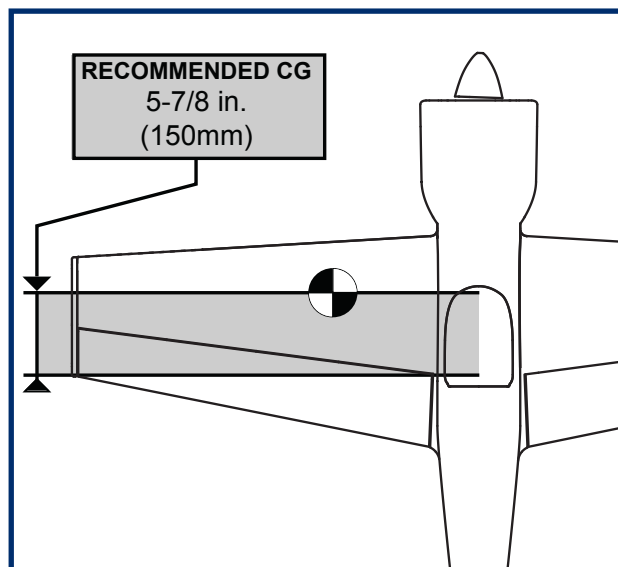

### ⚠ NOTICE

The CG measurement should be made with the completed airframe with all components (batteries, servos, receiver, linkages, screws, bolts, hardware, etc.) installed. Failure to do so will result in inaccurate measurement.

## PRE-FLIGHT CHECKLIST

To help ensure a successful first flight, as well as many flights after, perform a few simple pre-flight checks to be sure the aircraft is ready to fly:

1. Verify the ailerons, elevators and rudder are properly hinged and in good working order. Pinch a control surface between your thumb and forefinger and grasp the wing/stabilizer with your other hand. Attempt to move the control surface back and forth perpendicular to the stabilizer (see Figure 1). Watch the hinges for movement. If you find any loose hinges, apply Foam-Cure or 15/30 minute Epoxy, being sure to stay away from the hinge pivot, to the loose side(s) of the hinge(s) and re-insert into its location. **DO NOT apply thin CA to pin hinges!** Ensure that the hinge moves freely.
2. Verify all control surfaces move freely when disconnected from the servo. If you have a tight or binding surface, apply a small drop of light oil to each hinge pivot. Move the surface back and forth to work the oil into the hinge. Repeat as needed.
3. Verify that all hardware and other aircraft parts are properly secured, including those connections that require blue thread lock. This includes hardware and parts installed by the factory.
4. Verify your battery is fully charged and in good condition. Avoid using batteries with swollen cells, or batteries that do not charge back to their full capacity.
5. Verify that the CG is in the proper location and that the battery is secured in place.
6. Ensure the Aura is on and functioning properly. Power on your transmitter, followed by the aircraft. Ensure the Aura is calibrated properly and receiving a valid radio source (solid orange+solid green LEDs).
7. Verify transmitter stick inputs result in the proper control surface movements (reference page 18) and the Aura flight modes work properly.
8. Verify aircraft movement results in proper Aura sensor corrections (reference page 19).
9. Verify the motor and ESC function properly. Point the aircraft in a safe direction. Hold the airframe firmly, smoothly advance the throttle to full and back to idle. Listen and watch for any odd or unusual behavior for the motor or speed controller.

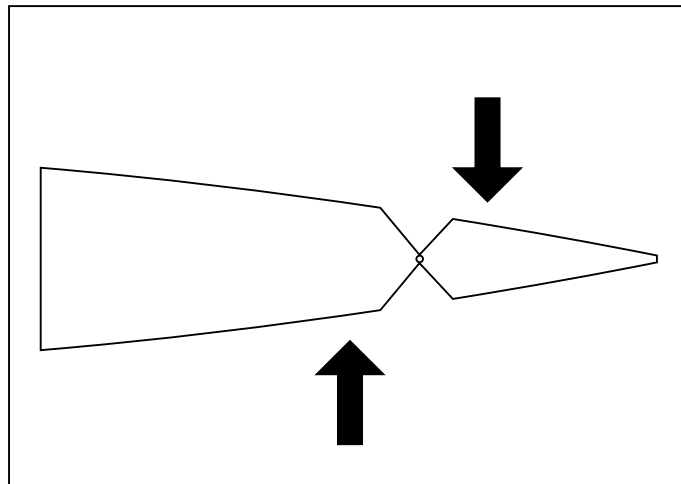

*Figure 1 - Test for hinge movement and loose hinges*

---

## AMA SAFETY CODE

When flying your aircraft, we recommend following the guidelines set by the Academy of Model Aeronautics (AMA). You can find their safety handbooks as well as more information on the AMA at their website, located at the address below:

[www.modelaircraft.org](http://www.modelaircraft.org)



## LASER 200 60E AURA OPTIONAL FEATURES CONFIGURATION

The Aura installed in your Laser 200 60E comes with the Quick Set feature. Quick Set allows the pilot to adjust options in the Aura without the use of a computer. The options of the Laser 200 60E are described below:

- Gyro Gain Kill switch: A switch can be used to immediately kill the Gyro Gain in case of emergency such as the Aura becoming unmounted in the aircraft.

To use this feature, you will need a minimum 7 channel transmitter.

### Laser 200 60E Optional Feature Transmitter Setup

**CH 7 (Aux 2) | Gyro Gain Kill Switch** (Optional) → Assign to 2-position switch  
**Flight Modes are as described in the table on page 12**

### Quick Set Procedure

#### Step 1 - Enter Quick Set Mode

1. Make sure all power is off on the Laser 200 60E
2. Remove the prop before making changes
3. Turn on your transmitter
4. Remove the Servo lead from Aura Port S2.
5. Install a bind plug in Aura Port S2.
6. Plug in the motor battery to power up the Laser 200 60E
7. After entering the Quick Set mode, the Orange LED will be off and the Green LED will be on SOLID. Initially the Blue LED will also be off.

#### Step 2 - Choose Option

After entering Quick Set mode as described above, you toggle the Gyro Gain Kill switch (CH7) on the transmitter to enable or disable this option.

8. If you want to activate the Gyro Gain Kill switch, toggle the CH7 switch on your transmitter .
  - If the Blue LED is ON, the Gyro Gain Kill switch is ENABLED .
  - If the Blue LED is OFF, the Gyro Gain Kill switch is DISABLED .

#### Step 3 - Saving your Selections

9. After setting the Gyro Gain Kill option as desired, remove the bind plug to save your settings. The Blue, Green, and Red LEDs will briefly turn on while the Aura is saving, then return to their previous state .
10. Completely power off the Laser 200 60E and Aura
11. Replace the Servo Lead in Aura Port S2
12. Power up and Fly with your updated Aura Settings!

Note: This process can be repeated as many times as desired to enable or disable the Gyro Gain Kill switch.



# FLYING YOUR LASER 200 60E

## Selecting a Flying Site

Selecting a flying site is critical to a successful flight. Airplanes require a lot more room than other R/C products, therefore, a neighborhood or parking lot is less than ideal. A large open field with short grass and generous overfly area are the best candidates if no AMA field is available in your area. Know your overfly area - ensure that there are no houses, playgrounds, or other buildings that may be damaged if the airplane were to crash.



## Takeoff

Taxi or place the aircraft on the runway centerline, with the nose pointed into the wind. Select Flight Mode 1, then set throttle trim so that the motor spins at its lowest RPM without stopping. Smoothly advance the throttle to full while maintaining directional control with the rudder and slight back pressure on the elevator. The airplane should lift off smoothly before the throttle is fully open. Fly in Flight Mode 1 until the aircraft is fully trimmed (see special trimming instructions), and you are comfortable with its handling, then explore the other modes as desired.

## Flying

Altitude is your friend on the first flight. Briskly climb to a safe altitude and trim the airplane out. The airplane should fly straight and level at 2/3 to 3/4 power with no hands on the transmitter. Try some basic maneuvers, and slowly progress into the airplane's flight envelope as you become more comfortable with the airplane's flight qualities and perfect your setup. Note: If at any time you experience unexpected control system inputs or oscillations, switch to Flight Mode 1 and reduce speed immediately, land and troubleshoot the issue.

## Landing

Be mindful of your flight time and allow adequate battery reserve for a couple of go-arounds, if necessary, on the first few flights. Select Flight Mode 1 and slow the airplane and align with the runway, into the wind. The airplane should descend smoothly in this configuration with proper airspeed. Once you are close to the ground, gradually close the throttle fully and begin to smoothly apply up elevator as required to arrest descent and the airplane should gently touch down with a short roll out.

### ! CAUTION

**USE CAUTION WHEN FLYING YOUR LASER 200 60E IN MODE 3 AT HIGH AIRSPEEDS. DOING SO WILL INDUCE CONTROL SURFACE OSCILLATIONS AND MAY CAUSE A CRASH.**

## Trimming

The first several flights on your new Laser 200 60E should be dedicated to trimming and setup. Fly the airplane at 2/3 power in Flight Mode 1 (Sport Mode) and trim for level flight. **DO NOT CHANGE FLIGHT MODES. Land, adjust linkages or execute Quick Trim (see below) and return the trim and/or sub-trim to zero and fly again. Repeat process until the airplane flies hands off, straight and level.**

Transmitter trim or sub-trim will cause trim shifts when different flight modes are selected. To eliminate this trim shift, the model should be mechanically trimmed, or Aura **Quick Trim** may be used instead.

## Aura Quick Trim

The Aura 8 features a Quick Trim Mode that eliminates the need for mechanical linkage adjustments during test flights. Aura will learn the trim values from your transmitter, and apply them to the control surfaces at power up when enabling quick trim mode.

NOTE: Quick Trim can also be used BEFORE flying to make small changes to center the control surfaces before flight.

1. Fly the airplane in Flight Mode 1, Sport Mode, at 2/3 power. Trim the aircraft with the transmitter trimmers and land. **DO NOT CHANGE FLIGHT MODES.**
2. Power off the Laser 200 60E. Insert a bind plug into Aura Port S3 (you will need to remove the servo lead that is currently in S3). Check the transmitter is on and re-power the Aura to enter Quick Trim.
3. Wait 5 seconds for the Aura to completely initialize. Confirm Quick Trim mode is active by checking the Blue LED is slowly flashing.
4. Remove the bind plug from Aura Port S3 to save your trim settings. The Blue LED will flash quickly after control surface trim values are stored. While the trim values are stored in Aura, they are not applied to the control surface(s) until the Aura is re-powered.
5. Remove power from the Laser 200 60E and center all control surface trims on the transmitter.
6. Re-install the servo that was previously removed into port S3.
7. Re-power the Laser 200 60E. The control surfaces should be unchanged even though the trim has been centered on the transmitter.
8. Switch between other Flight Modes to ensure you do not see any changes in trim.

NOTE: QUICK TRIM MAY BE REPEATED AS NEEDED FOR FINE TUNING, OR IF CHANGES TO THE AIRCRAFT ARE MADE.

NOTE: ENSURE AILERON/ELEVATOR/RUDDER SUB-TRIMS ARE AT ZERO IN THE TRANSMITTER **BEFORE** FLYING FOR THE QUICK TRIM PROCESS TO WORK PROPERLY.

## AIRFRAME REPAIRS

The Laser 200 60E is molded from durable EPO foam and is repairable with most adhesives. Similar to building and repairing wood or composite airplanes, the correct glue for a given application is critical to the repair holding and not breaking again. For major repairs, such as a broken fuselage, epoxy is preferred because it allows time to correct any misalignment. For smaller repairs, such as a cracked control surface or small chunk of material missing from the airframe, regular CA is very effective. The use of odorless (foam safe) CA is not required and not recommended on EPO foam aircraft because it takes a longer period of time to cure than regular CA and the bond tends to be weaker.

**NOTE:** Avoid the use of CA accelerant in repairs. It can damage paint and will weaken the bond of the glue. If CA accelerant is used, be mindful of the locations of CA to prevent premature bonding of parts, or bonding a hand or clamp to the airframe.

If a part is damaged too badly to be repaired, please refer to the table on page 3 for a complete listing of spare airframe parts.

### WARNING

**Note: Do not use thread locker on any metal to plastic connection including the bolts holding the push rods to the servos or the control horns (they use lock nuts and will not back out)!**

**Using thread locker will weaken the plastic, void your warranty, and cause your airplane to crash!**

### NOTICE

If a crash is imminent, fully reduce the throttle to prevent further damage to the power system and reduce energy to lessen impact damage. Never allow the propeller to contact the ground under power, even idle.

***CRASH DAMAGE IS NOT COVERED UNDER ANY PRODUCT WARRANTY.***

**NOTE:** Avoid keeping the airplane in direct sunlight when not flying. Excessive heat can damage the airplane's structure and UV damage can permanently discolor decals.

---

## REPLACING SERVOS

**Required Tools and Fasteners:** #1 Phillips Screwdriver

1. Disconnect the servo from the Aura 8.
2. Unscrew the servo arm from the servo and remove the servo arm.
3. Unscrew the two servo mounting screws at each end of the servo and remove. Note that some servos may be connected to a servo extension. This extension should be left in the wing or fuselage when the servo is replaced.

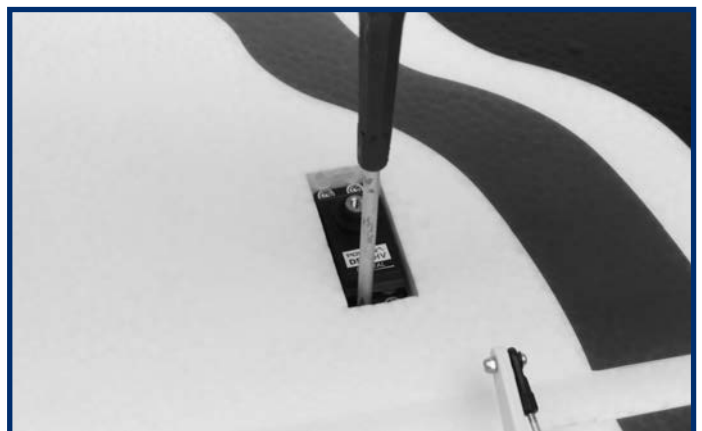
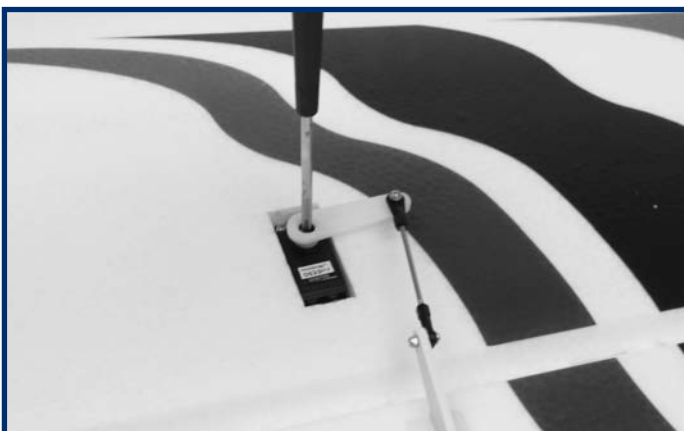

# AIRCRAFT TROUBLESHOOTING GUIDE

Should you encounter any abnormal situations with your Laser 200 60E, refer to the table below to determine the probable cause and a recommended solution for the issue. If the required solution does not rectify the problem, please contact product support at support@flexinnovations.com for further assistance.

## ! NOTICE

Unless specifically required, ALWAYS troubleshoot the airplane with the propeller removed.

DISCREPANCY	PROBABLE CAUSE	RECOMMENDED SOLUTION
Motor non-responsive (no ESC initialization tones audible)	Throttle not at idle and/or throttle trim too high	Lower throttle stick and trim completely. If problem persists, ensure that the sub-trim and travel adjust are properly set in the radio's programming
	Motor disconnected from ESC	Ensure plugs are fully seated. Check battery and/or plugs for damage and replace any damaged components found - DO NOT ATTEMPT REPAIR
Motor non-responsive (throttle calibration tones received)	Throttle channel is reversed	Reverse throttle channel in radio programming
Motor turns in the wrong direction	The three motor wires are connected incorrectly to the ESC	Swap any TWO motor wires
Reduced flight time or aircraft underpowered	Battery not fully charged	Ensure battery is fully charged prior to installing in aircraft
	Propeller installed backwards	Install propeller so that the convex side faces forward (tractor configuration)
	Battery is too weak or damaged	Remove battery from service completely and replace with a different battery
	Ambient temperature is too cold	Ensure battery packs are adequately warm (70°F/21°C) before flight
	Battery capacity too small for intended use	Replace battery with one of proper capacity and discharge capacity
	ESC reaching preset LVC (low-voltage cutoff)	Recharge flight battery or reduce flight time
	Battery's discharge rating may be too small	Replace battery with one with higher 'C' rating
Excessive propeller noise and/or vibration	Damaged spinner and/or propeller, collet, or motor	Replace damaged components - DO NOT ATTEMPT REPAIR
	Propeller is not balanced	Balance or replace the propeller
	Prop nut is loose	Tighten prop nut with appropriate-sized wrench
	Spinner is not fully in place or tightened	Loosen the spinner bolt, adjust as required, retighten spinner bolt
	Propeller nut or propeller adapter threads not cut straight	Replace propeller nut or propeller shaft - DO NOT ATTEMPT REPAIR
Control surfaces nonresponsive	Airframe or control linkage system damage	Examine airframe for damage, repair as required; inspect control linkage system (servo, pushrod, control horn) for damaged components and replace as required
	Wire damaged or connector loose	Examine wires and connections, replace as necessary
	Transmitter bound incorrectly, incorrect active model memory, incorrect Aura data input configuration, incorrect Aura transmitter settings	Consult radio manual for proper binding and model selection instructions
	Battery voltage too low	Use volt meter to check battery; recharge or replace as necessary
	Battery disconnected from ESC	Check that the ESC plugs are fully seated
	BEC (battery elimination circuit) damaged	Replace ESC - DO NOT ATTEMPT REPAIR
	Damaged Servo	Replace Servo - DO NOT ATTEMPT REPAIR
Failed control direction test	Incorrect Aura 8 or Transmitter Setting - DO NOT FLY!	Reference transmitter and receiver sections of this manual. Refer to control surface direction chart and transmitter setup; adjust appropriate settings as required. Check Laser 200 60E and Aura wiki web pages for additional information. If no solution is found, contact customer support at support@flexinnovations.com
Failed Sensor Direction Test	Aura 8 is not mounted in the proper orientation	Mount Aura in the proper orientation
	Aura 8 settings incorrect	Reference the transmitter and receiver sections of this manual. If no is solution is found, contact customer support at support@flexinnovations.com
Control surface oscillation	Exceeding maximum airspeed for configuration	Reduce airspeed
	Gains too high for aircraft/flight configuration	Refer to Aura 8 manual to decrease desired control surface gain
	Propeller/spinner not balanced	Balance or replace propeller and/or spinner
	Motor vibration	Inspect motor mounting bolts and re-tighten as necessary
	Loose Aura 8 mounting	Re-align and secure the Aura 8 to the aircraft
	Control linkage slop	Examine control system and repair or replace worn components
	Improper transmitter setup	Refer to Aura 8 manual to correctly configure transmitter
	Damaged propeller or spinner	Replace damaged component- DO NOT ATTEMPT REPAIR
	Improperly set master gain	Ensure master gain is set for proper gain value
Trim changes between flight modes	Trims are not properly zeroed	Readjust control linkage and re-center trims in radio
	Sub-trim is not properly zeroed	Remove sub-trim; adjust the servo arm or clevis to achieve proper geometry
	Transmitter is not properly calibrated (aileron/elevator/rudder are not neutral with sticks centered; reference transmitter monitor)	Calibrate transmitter (reference manufacturer's instructions, or return to manufacturer for calibration)
Gyro doesn't respond to aircraft movements	Note: Gyro Kill is only available after enabling it using the quick set procedure, see page 23 for details on enabling gyro kill	
	Gyro kill switch not setup on transmitter	Follow the transmitter configuration guide, assign CH7/Aux2 to a two-position switch
	Gyro kill switch in gyro off position	Move the gyro kill switch to the on position

# LIMITED WARRANTY

## Warranty Coverage

Flex Innovations LLC and its authorized resellers (“Flex”) warrant to the original purchaser that this product (the “Product”) will be free from defects in materials and workmanship at the date of purchase.

## Outside of Coverage

The warranty is not transferable and does not cover:

- (a) Products with more than 45 days after the purchase date
- (b) Damage due to acts of God, accident, misuse, abuse, negligence, commercial use, or due to improper use, installation, operation, or maintenance
- (c) Damage to other components or assemblies associated with the use of the Product.
- (d) Modification of or to any part of the Product
- (e) Product not purchased from an authorized Flex Innovations dealer or distributor.
- (f) Product that has been partially, or fully assembled
- (g) Shipping damage
- (h) Cosmetic damage
- (i) Services or labor associated with the repair, use or assembly of the Product.

**OTHER THAN THE EXPRESS WARRANTY ABOVE, FLEX MAKES NO OTHER WARRANTY REPRESENTATION, AND HEREBY DISCLAIMS ALL IMPLIED WARRANTIES, INCLUDING, WITHOUT LIMITATION, THE IMPLIED WARRANTIES OF NONINFRINGEMENT, MERCHANTABILITY AND FITNESS FOR A PARTICULAR PURPOSE. THE PURCHASER ACKNOWLEDGES THAT THEY ALONE HAVE DETERMINED THAT THE PRODUCT WILL SUITABLY MEET THE REQUIREMENTS OF THE PURCHASER’S INTENDED USE.**

## Purchaser’s Remedy

Flex’s sole obligation and purchaser’s sole and exclusive remedy shall be that Flex will, at its option, either (i) service, (ii) replace any part of the Product determined by Flex to be defective, or (iii) replace the Product determined by Flex to be defective. Flex reserves the right to inspect all Product(s) involved in a warranty claim. Service or replacement decisions are at the sole discretion of Flex. Proof of purchase is required for all warranty claims. **SERVICE OR REPLACEMENT AS PROVIDED UNDER THIS WARRANTY IS THE PURCHASER’S SOLE AND EXCLUSIVE REMEDY.**

## Limitation of Liability

**FLEX SHALL NOT BE LIABLE FOR SPECIAL, INDIRECT, INCIDENTAL OR CONSEQUENTIAL DAMAGES, LOSS OF WAY, REGARDLESS OF WHETHER SUCH CLAIM IS BASED IN CONTRACT, WARRANTY, TORT, NEGLIGENCE, STRICT LIABILITY OR ANY OTHER THEORY OF LIABILITY, EVEN IF FLEX HAS BEEN ADVISED OF THE POSSIBILITY OF SUCH DAMAGES.**

Further, in no event shall the liability of Flex exceed the individual price of the Product on which liability is asserted. As Flex has no control over use, setup, assembly, modification or misuse, no liability shall be assumed nor accepted for any resulting damage and/or injury. By the act of use, setup or assembly, the user accepts all resulting liability. If you as the purchaser or user are not prepared to accept the liability associated with the use of the Product, purchaser is advised to return the Product immediately in new and unused condition to the place of purchase.

## Law

These terms are governed by Florida law (without regard to conflict of law of principals). This warranty gives you specific legal rights, and you may also have other rights which vary from state to state. FLEX RESERVES THE RIGHT TO MODIFY THIS WARRANTY AT ANY TIME WITHOUT NOTICE.

## Questions & Assistance

Contact Us By:

E-Mail – support@flexinnovations.com

Phone – 1 (866) 310-3539

## Inspection or Services

If this Product needs to be inspected or serviced and is compliant in the region you live and use the Product in, please contact your regional Flex authorized reseller. Pack the Product securely using the original shipping carton. Please note that both the inner and outer boxes need to be included. The inner box is not designed to withstand the rigors of shipping without additional protection from the outer shipping carton. Ship via a carrier that provides tracking and insurance for lost or damaged parcels, as Flex is not responsible for merchandise until it arrives and is accepted at our facility.

## Warranty Requirements

For Warranty consideration, you must include your original sales receipt verifying the proof of purchase date. Provided any warranty conditions have been met, your Product or its defective parts will be replaced or serviced free of charge. Responsibility of shipping charges are as follows:

To Flex from customer, Customer is responsible.

To Customer from Flex, Flex is responsible.

Service or replacement decisions are at the sole discretion of Flex.

## COMPLIANCE INFORMATION FOR THE EUROPEAN UNION

	Declaration of Conformity (In accordance with ISO/IEC 17050-1)	
	Product(s):	Laser 200 60E Super PNP
	Item Number(s):	FPM5170A
		FPM5180A
		FPM5170B
		FPM5180B

The object of declaration described above is in conformity with the requirements of the specifications listed below, following the provisions of the EMC Directive 2004/108/EC.

- EN 55022: 2010+AC: 2011
- EN 55024: 2010
- EN 61000-3-2: 2006+A2:2009
- EN 61000-3-3: 2013
- EN 61000-6-3: 2007/A1:2011
- EN 61000-6-1: 2007



## Instructions for disposal of WEEE by users in the European Union

This product must not be disposed of with other waste. Instead, it is the user’s responsibility to dispose of their waste equipment by handing it over to a designated collections point for the recycling of waste and electronic equipment. The separate collection and recycling of your waste equipment at the time of disposal will help to conserve natural resources and ensure that it is recycled in a manner that protects human health and the environment. For more information about where to drop off your waste equipment for recycling, please contact your local city office, your household waste disposal service or where you purchased the product.

# Building and Flying Notes

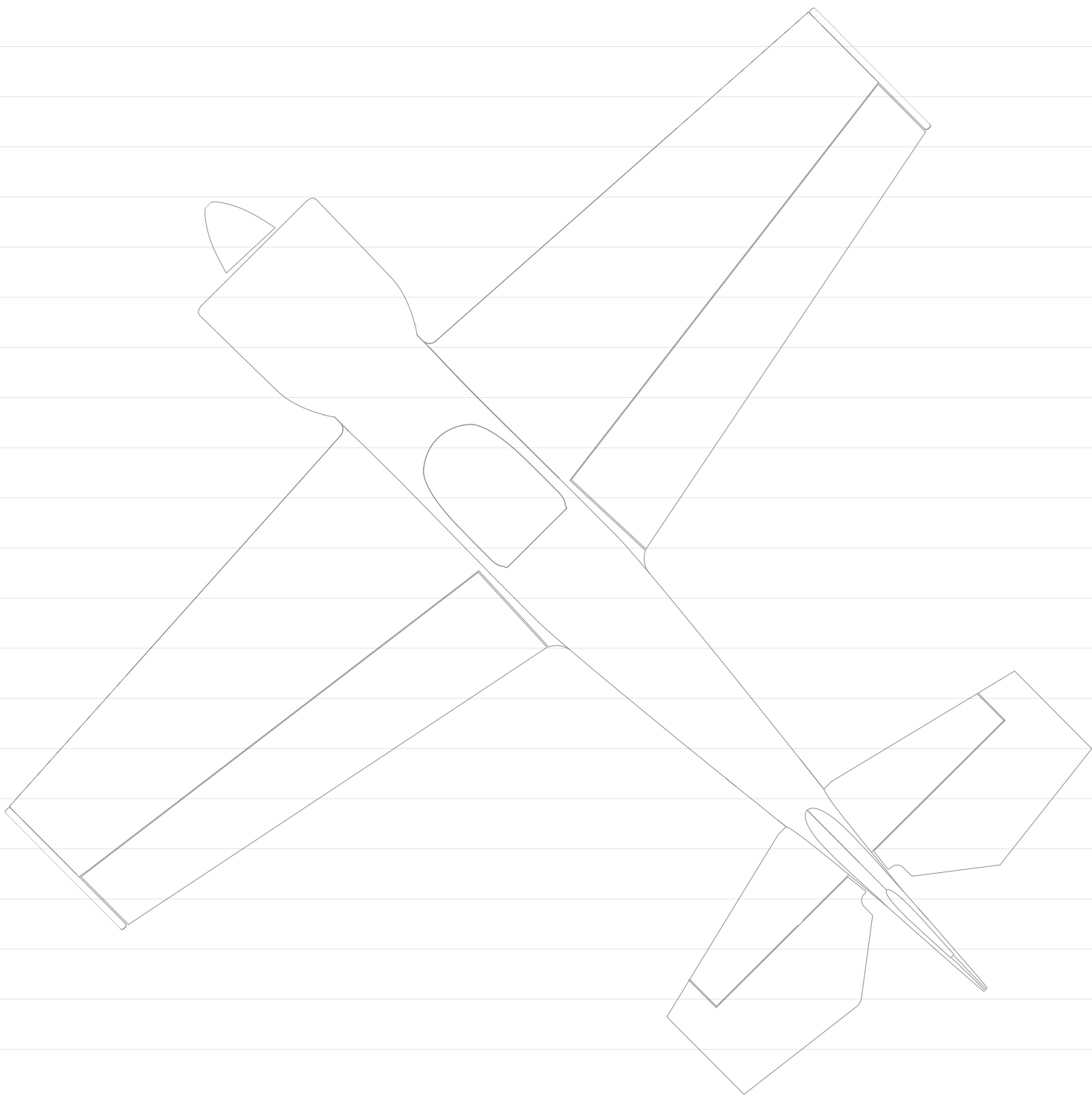

*Enjoy your Flex Innovations Laser 200 60E!*

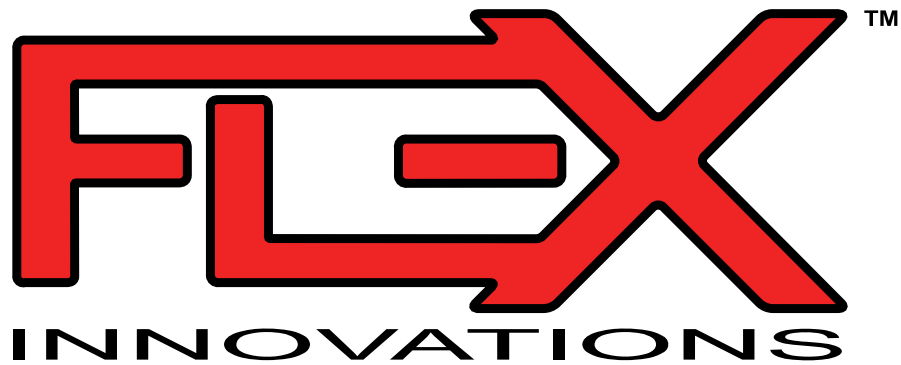

[www.flexinnovations.com](http://www.flexinnovations.com)

© 2024 Flex Innovations, LLC. All rights reserved.

Potenza™ is a trademarks of Flex Innovations LLC

DSM®, DSM2™, and DSMX™ are trademarks of Horizon Hobby, Inc.

Futaba is a registered trademark of Futaba Denshi Kogyo Kabushiki Kaisha Corporation of Japan.

Jeti, UDI, and Jeti Model are trademarks or registered trademarks of Jelen, Ing. Stanislav of Czech Republic

HoTT is a registered trademark of SJ, Inc.